



BITSTREAM®

Lider rozwiązań synchronizacji czasu i transmisji danych



Ethernet Switch HYPERION-300

Industrial switch with support for openDNP3 in slave mode and DLMS for communication with measurement units.



Reliable



Industrial



Easy to configure



Solid

Hyperion-300

Managed Industrial Ethernet switch with 10 ports and additional control and measurement interfaces

- ✓ Available interfaces:
 - 2x 100M/1000M/2.5G SFP + 6x 100M/1000M SFP + 2x 10M/100M/1G RJ45
- ✓ Work in a ring compliant with the ITU-T G.8032 standard with reconfiguration < 20ms , up to 64 rings simultaneously
- ✓ In the HYPERION-302.2 version, the following profiles for precise time synchronization based on the IEEE1588 v.2 (PTPv.2) standard are available: default 1588, G.8265.1 and G.8275.1
- ✓ NTP protocol in server/client mode and SNTP
- ✓ Optional control and measurement functions:
 - interfaces 1x RS232/485 and 2x RS232, 1-Wire (T/H), 2x digital input, 4x relay outputs.
- ✓ Support for external **MOD-EXT-IO module** for increased number of I/O interfaces and DC voltage measurement (Module support is available in the Hyperion-30x-3 version. The use of an extension module excludes the use of a T/H sensor.
- ✓ Energy saving with **Energy Efficient Ethernet 'EEE' technology**
- ✓ **Radius** - centralized authentication
- ✓ Support for **PROFINET Class A, DNP3** and **DLMS protocols**
- ✓ Ethernet **OAM** support (**Link OAM and Service OAM**)
- ✓ Access security **SNMPv3, HTTPS, SSH**
- ✓ Additional optional security mechanisms
- ✓ Operating temperature: **-40 to +85°C** when conditions are met
- ✓ **IP-30 DIN** resistant metal housing
- ✓ **DC** redundant power supply
- ✓ **AC** power

Licensed optional features

- ✓ Extension in the **IEEE 1588-2008v.2 (PTPv2)** protocol with profiles **Power Profiles** ; real-time synchronization for energy applications in accordance with **IEEE C37.238-2011, C37.238-2017 standards; IEC61850-9-3** ,
- ✓ **Synchronous Ethernet G.8261** (only available in 30x.2 version)

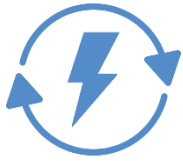

Energy saving

Thanks to the use of Energy Efficient Ethernet technology compliant with IEEE 802.3az, the Hyperion-300 device can significantly reduce energy consumption by optimizing the operation of interfaces based on port traffic load and allows the electrical port to go into sleep mode if the device connected to it does not generate traffic.



Easy to configure

BitStream devices and software have been designed to be as user-friendly as possible for the network administrator and installer. From the very first moment, you can configure it in an intuitive way, despite having a lot of functionalities . Built-in HTTPS server, SSH server allows for safe configuration of device parameters via a standard web browser or command line, and thanks to the built-in SNMPv.3 agent, monitoring from any management platform equipped with the SNMP protocol.



Durable

The Hyperion-300 device has been designed to cope with operation in extreme climatic conditions. Resistant metal housing with IP-30 protection, guarantee protection against mechanical damage. Moreover, the device is adapted to work in the temperature range from -40°C to +85°C with the conditions met.



Guaranteeing connection redundancy

The Hyperion-300 switch supports Ethernet Ring Protection technologies Switching (ERPS) compliant with the ITU-T G.8032 standard, enabling operation with redundancy of the transmission path with reconfiguration time less than 20ms with support for up to 64 rings.



Dependable

The Ethernet switch has two power connectors . The redundant power supply function guarantees stable and continuous operation in case of failure of one of the power sources.

Supported transmission standards

- ✓ IEEE 802.3 10Base-T Ethernet
- ✓ IEEE 802.3u 100Base-TX Fast Ethernet
- ✓ IEEE 802.3u 100Base-FX Fast Ethernet Fiber
- ✓ IEEE 802.3ab 1000Base-T
- ✓ IEEE 802.3z Gigabit Fiber
- ✓ IEEE 802.3x Flow Control and Back pressure
- ✓ IEEE 802.1AB Link Layer Discovery Protocol (LLDP)
- ✓ IEEE 802.1p Class of Service (CoS)
- ✓ IEEE 802.1Q VLAN
- ✓ IEEE 802.1ad QinQ
- ✓ IEEE 802.1D Spanning Tree Protocol (STP)
- ✓ IEEE 802.1D-2004 Rapid Spanning Tree Protocol (RSTP)
- ✓ IEEE 802.1s Multiple Spanning Tree Protocol (MSTP)
- ✓ IEEE 802.3ad Link Aggregation Protocol (LACP)
- ✓ IEEE 802.1x Port Based Network Access Protocol
- ✓ IEEE 802.3az EEE

Supported protocols

- ✓ IPv4, IPv6, ARP, ICMP, TCP, UDP, DNS,
- ✓ IGMP v1, v2, v3, MLD v1, v2, GVRP,
- ✓ SNMPv1/v2c/v3,
- ✓ DHCP client/server ,
- ✓ NTP client/server, SNTP,
- ✓ HTTP, HTTPS, Telnet, SSH v2, Syslog ,
- ✓ EtherNet /IP, SNMP Inform, LLDP, RMON,
- ✓ IEEE1588 PTP v2 (only available in version 30x.2),
- ✓ Synchronous Ethernet **G.8261** (only available in 30x.2)
- ✓ MIB-II, Ethernet- Like MIB
- ✓ IEEE 802.1x Port Based Network Access Protocol, EAP, TACACS+, RADIUS, NAS
- ✓ OpenDNP3 (IEEE-1815, DNP3)
- ✓ DLMS

Supported standards, recommendations and directives for EMC, safety*

EN 55011:2016-05/A11:2020-07	Industrial, scientific and medical devices	Radio frequency disturbance characteristics - Limits and methods of measurement.
EN 61000-6-2:2019-04	ElectroMagnetic Compatibility (EMC)	
EN 55035:2017-09	Electromagnetic compatibility of multimedia devices	Resistance requirements
EN IEC 62368-1:2020-11	Audio/visual, IT and telecommunication devices	Part 1: Safety requirements
EN 60825-1:2014-11	Laser safety Part 1: Equipment classification and requirements.	
EMC 2014/30/EU	EMC Electromagnetic Compatibility Directive.	
LVD 2014/35/EU	Low Voltage Directive LVD.	
IEC 61000-4-2	Electromagnetic Compatibility (EMC)	Part 4-2: Testing and measurement methods - Electrostatic discharge immunity test.

IEC 61000-4-3	Electromagnetic Compatibility (EMC)	<i>Part 4-3: Testing and measurement methods - Radiated radio frequency electromagnetic field immunity test.</i>
IEC 61000-4-4	Electromagnetic Compatibility (EMC)	Part 4-4: Immunity test against bursts of fast electrical transients.
IEC 61000-4-5	Electromagnetic Compatibility (EMC)	Part 4-5: Test and measurement methods - Shock resistance test.
IEC 61000-4-6	Electromagnetic Compatibility (EMC)	Part 4-6: Test and measurement methods - Immunity test against conducted disturbances induced by radio frequency fields.
IEC 61000-4-8	Electromagnetic Compatibility (EMC)	Part 4-8: Power frequency magnetic field immunity test.
IEC 61000-4-11	Electromagnetic Compatibility (EMC)	Part 4-11: Tests for immunity to voltage dips, short interruptions and changes in voltage.
IEC 61000-4-12	Electromagnetic Compatibility (EMC)	Part 4-12: Test and measurement methods - Damped sinusoidal immunity test.
IEC 61000-4-29	Electromagnetic Compatibility (EMC)	Part 4-29: Test of immunity to voltage dips, short interruptions and changes in voltage at the DC power supply connection.
EN 61000-6-2:2019-04	ElectroMagnetic Compatibility (EMC)	Part 6-2: General Standards - Immunity standard for industrial environments
EN 61000-6-5:2016-01	ElectroMagnetic Compatibility (EMC)	Part 6-5: General standards - Immunity for equipment used in power station and substation environments
EN 61850-3:2005	Communication systems and networks in electrical substations	Part 3: General requirements

* - The scope and list of supported standards may change as the device develops

Ethernet interfaces

- ✓ connectors : 2x SFP 100/1000M/2.5Gbps, 6x SFP 100/1000Mb/s, 2x RJ45 10/100/1000Mb/s, (speed 100Mb/s on Optical Interface works only with optical SFP inserts)
- ✓ Matrix switching capacity: 20Gbps
- ✓ Forwarding : 17.9 Mpps
- ✓ QoS : Support 8 physical queues, Weighted algorithm Round Robin and Strict queuing priority . Priority settings based on: PCP 802.1p priorities, DSCP/ToS , port priorities settings, ability to configure priorities based on TCP/UDP port numbers
- ✓ VLAN: 4096 VLAN entries, 802.1Q, 802.1QinQ, private VLAN, VLAN translation
- ✓ Throughput control: inbound filtering for Broadcast, Multicast, Unknown DA or all packets, outbound filtering for all packet types, throughput limiting
- ✓ IGMP snooping V1/V2/V3, IGMP Filtering/Throttling, IGMP query, IGMP proxy reporting, MLD snooping V1/V2
- ✓ RMON, MIB II, Port mirroring, DNS, IEEE802.1ab LLDP, LLDP-MED
- ✓ Syslog - cooperation with the syslog server ,
- ✓ Port Mirroring: Monitor traffic on selected ports
- ✓ IEEE 802.3az: Energy Efficient Ethernet, 4 power saving modes
- ✓ Trunk Port : IEEE 802.3ad LACP or Static Aggregation
- ✓ MAC address table: up to 8192 entries
- ✓ IEEE 802.1x Port Based Network Access Protocol , EAP, TACACS+, RADIUS - Authentication, Authorization and Accounting - AAA
- ✓ Security: HTTP/HTTPS, SSL/SSH
- ✓ Network Redundancy:
 - ITU-T G.8032 Ethernet Ring (ERPS)
 - IEEE 802.1D Spanning Tree (STP)
 - IEEE 802.1D-2005 Rapid Spanning Tree Protocol (RSTP)
 - IEEE 802.1s Multiple Spanning Tree Protocol (MSTP)

T-wire interface

- ✓ speed 0 - 16.3 kbps
- ✓ Range ≤ 100m
- ✓ Connector: RJ45
- ✓ Input dedicated to MOD-EXT-IO module or T/H sensor

RS232/485 interfaces

- ✓ UDP/TCP; server/client
- ✓ Transmission speed:
 - 0-115.2 kbps for RS232
 - 0-230 kbit /s for RS485
- ✓ Interface type configuration:
 - 2x port with RS232 and 1x port with RS232/485 interface - 2/4 wire
- ✓ Connector: RJ45
- ✓ Galvanic isolation between interfaces

Digital outputs

- ✓ Number of outputs - 4
- ✓ Output type - "relay contact"
- ✓ Maximum switching current - 0.5A 48VDC
- ✓ Connector: RJ45

Digital inputs:

- ✓ Number of inputs - 2
- ✓ Galvanically isolated inputs
- ✓ Input type - dry contact
- ✓ Connector: RJ45

Network synchronization

- ✓ NTP protocol in server/client mode and SNTP
- ✓ IEEE 1588-2008 v2 PTP - In version 30x.2, the following IEEE1588 v.2 (PTPv.2) based precision time synchronization profiles are available: default 1588, G.8265.1 and G.8275.1 in the following modes
 - ✓ Transparent clock (TC): peer to peer, end to end with one step, two step;
 - Time error typically 50ns
 - ✓ borders clock (BC);
 - Time error for BC (Boundary clock) typically < 200ns
- ✓ In version 30x.2 under license support Synchronous Ethernet, G.8261

MTBF

- ✓ Time : 628000 hours
- ✓ Standard: Telecordia , SR-332

Management

- ✓ SNMPv1/2c/3, SSH
- ✓ HTTP/HTTPS protocol - management via a web browser
- ✓ Local CLI console (RS232) - USB connection
- ✓ " Privilege level " - permission level configuration - read/write, independently configured for many users

Power

- ✓ DC power supply, 12-60V VDC /0.95-0.16A (9.5W)
- ✓ Two power inputs, redundant power supply for DC power supply
- ✓ DC/AC power adapter, 100-350VDC/85-240VAC (version available only without PoE function)
- ✓ Screw connection for AC or DC power

Physical features

- ✓ Can be mounted on a DIN rail
- ✓ IP-30 metal housing
- ✓ Dimensions 135x125x99mm
- ✓ Weight 0.90 kg

Work environment requirements

- ✓ Operating temperature: -40 to +85°C with air flow of at least 0.4m/s
- ✓ Operating temperature: -40 to +70°C with air flow of at least 0.0m/s
- ✓ Working time at a maximum temperature of +85°C is up to 16 hours,
- ✓ Standard operating humidity: 0 to 95% (non-condensing)
- ✓ Location type: class C according to the standard,
- ✓ PN-EN 60870-2-2 - sheltered locations,
- ✓ Degree of protection in accordance with IP-30

Mechanical drawing

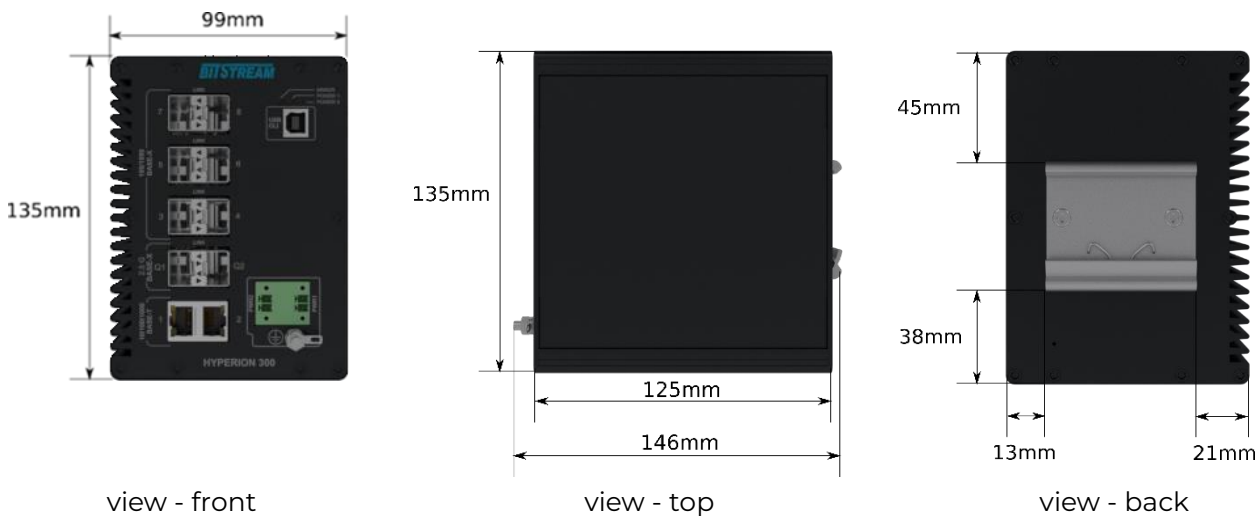

HYPERION-30X(.Y)-Z-U

HYPERION	30X	(.Y)	Z	U
2x RJ45(10M/100M/1G) + 6x SFP(100M/1G) + 2x SFP(100M/1G/2.5G)	2			
Production version:				
standard		-		
version dedicated to power substations		2		
Additional interfaces				
basic version			1	
2x digital input, 4x relay outputs, 1-wire interface, 2xRS232 and 1xRS232/485			3	
Power				
Redundant power supply 12-36V DC				66p
Redundant power supply 20-60V DC				77p ²
Power supply 100-350VDC/85-240VAC				B ¹

Legend

1 - The selected version requires contact with the manufacturer

Sample markings

HYPERION-302.2-3- 66p

Hyperion-300 in a version dedicated to power substations with 2xRJ45 and 6xSFP and 2xSFP 2.5Gb with redundant power supply 12-36VDC and with PTPv2 IEEE 1588:2008, 1x digital input, 4x relay outputs, 1-wire interface, 1xRS232/485 and 2xRS232, ready to run SYNCE,

Licenses that extend the capabilities of the Hyperion-30x.2 switch

1. **PTP SYNCHRONIZATION LICENSE with POWER PROFILE** - license extending the IEEE1588 PTPv2 protocol with the POWER PROFILE profile - IEEEC37.238-2011, IEEEC37.238-2017 and IEC61850-9-3 for precise time synchronization, among others, for use in the power industry.
2. **SYNCE LICENSE - Synchronous Ethernet G.8261** - license to add functionality Synchronous Ethernet G.8261 (Timing and synchronization aspects in packet networks), ensuring precise synchronization of internal clocks of devices using frequencies, among others, for use in the power industry.

NOTE: license available only in version 30x.2

Note: The product is available for sale starting from a minimum quantity of 30 units.

Additional accessories

Designation	Transmission speed	Wavelength	Fiber type	Distance	Cartridge type	WDM	Connector type	Working temperature	Comments
BTP-8524-S5TD	1.25 Gb/s	850nm	MM	550 m	SFP	—	LC	-40~ 85 °C	—
BTP-3124-L2TD	1.25 Gb/s	1310nm	MM/SM	2/20km	SFP	—	LC	-40~ 85 °C	—
BTP-3124-L4TD	1.25 Gb/s	1310nm	SM	40 km	SFP	—	LC	-40~ 85 °C	—
BTPP-85192-SRT	10 Gb/s	850 nm	MM	300 m	SFP+	—	LC	-40~85°C	support 2.5Gb
BTPP-31192-LRT	10 Gb/s	1310 nm	SM	10 km	SFP+	—	LC	-40~85°C	support 2.5Gb
BTPB-3503L-L2TD	155 Mb/s	1310/1550 nm	SM	20 km	SFP	YES	LC	-40~85°C	—
BTPB-5303L-L2TD	155 Mb/s	1550/1310 nm	SM	20 km	SFP	YES	LC	-40~85°C	—
BTPB-3524S-L2TD	1.25 Gb/s	1310/1550nm	SM	20km	SFP	YES	SC	-40~ 85 °C	—
BTPB-5324S-L2TD	1.25 Gb/s	1550/1310nm	SM	20km	SFP	YES	SC	-40~ 85 °C	—
BTP-8503-02TD	155 Mb/s	850nm	MM	2 km	SFP	—	LC	-40~ 85 °C	—
BTP-3103-02TD	155 Mb/s	1310nm	MM	2 km	SFP	—	LC	-40~ 85 °C	—
BTP-3103-L2TD	155 Mb/s	1310nm	SM	20 km	SFP	—	LC	-40~ 85 °C	—
LT-19-TS-35-02	19" DIN rail in a housing that allows mounting in a rack cabinet . Dimensions: 19" x 3U x 202-302mm (adjustable depth). Weight: 2.5kg. 4pcs Vertical Hyperion-300								
Sensor T/H-2/5/10	temperature and humidity measurement, cable length up to 2/5/10 meters (possibility of connecting up to two sensors)								
MOD-EXT-6I2O3V-H300	External module extending IO functions with digital inputs and digital outputs as well as voltage measurement inputs, operating temperature: -40~ +70°C, power supply 9-60V DC (NOTE - only for HYPERION-30x-3 version)								

List of proposed power supplies for BITSTREAM devices

Power supply designation	Output voltage range	Nominal output power	Number of ports with PoE (15W)	Number of ports with PoE + (30W)	Number of ports with PoE ++ (60W)	Number of ports with PoE ++ (90W)	Working temperature		Comments
	DC						C-standard	T-industrial	
ZAS-24-20-RT	24V	20W	0	0	0	0	-20°C ~ +70°C	No PoE support	
ZAS-48V56-40-RT	48 - 56V	40W	2	1	0	0	-20°C ~ +70°C	PoE support	
ZAS-48V56-60-RT	48 - 56V	60W	3	1	0	0	-20°C ~ +70°C	PoE support	
ZAS-48V55-120-RT	48 - 55V	120W	6	3	1	1	-20°C ~ +70°C	PoE support	
ZAS-48V56-240-RT	48 - 56V	240W	13	6	3	2	-20°C ~ +70°C	PoE support	
ZAS-48V56-480-RT	48 - 56V	480W	30	14	7	4	-20°C ~ +70°C	PoE support	

Legend of markings: W – plug-in; S – standalone ; R - for DIN rail



Bitstream S.A.

Mełgiewska St. 7/9
20-209 Lublin, Poland
Vat: 946-250-85-88
Tel. +48 81 743 86 43
Fax +48 442 02 98
info@bitstream.pl
www.bitstream.pl/en



All rights reserved.
Specifications may
change during
development.